



## Model SPIDER 50-75

	
<b>SAFETY BELT SANDER</b>	<b>SAFETY BELT SANDER</b>
<ul style="list-style-type: none"> <li>1.0 Introduzione</li> <li>2.0 Dati tecnici</li> <li>3.0 Installazione</li> <li>4.0 Funzionamento/uso</li> <li>5.0 Certificazione</li> <li>6.0 Identificazione</li> <li>6.1 Controllo qualità</li> <li>7.0 Manutenzione</li> <li>8.0 Cond.di stoccaggio</li> <li>8.1 Smaltimento</li> <li>9.0 Disegno+Esploso</li> <li>10.0Esempio di montaggio</li> </ul>	<ul style="list-style-type: none"> <li>1.0 Introduction</li> <li>2.0 Technical Data</li> <li>3.0 Installation</li> <li>4.0 Operation and use</li> <li>5.0 Certification</li> <li>6.0 Identification</li> <li>6.1 Quality control</li> <li>7.0 Maintenance</li> <li>8.0 Storage conditions</li> <li>8.1 Disposal</li> <li>9.0 Design anddetailedview</li> <li>10.0Exemple of assembly</li> </ul>

<p><b>1.0</b> <b>Introduzione</b></p> <p>Uno strumento per la levigatura e la sbavatura su torni convenzionali. Infatti, si può levigare senza l'uso diretto delle mani (per la sicurezza). L'utensile viene fissato all'attrezzo esistente dei torni convenzionali. Permette operazioni di levigatura di parti metalliche, leghe e legno. Una manovella azionata manualmente permette la rotazione della cinghia abrasiva (questo indice è necessario per una levigatura più efficiente). Questo utensile è progettato per adattarsi ai diversi diametri delle parti . Permette inoltre di cambiare rapidamente la cinghia abrasiva (dettagli 4.0).</p>	<p><b>1.0</b> <b>Introduction</b></p> <p>A tool for sanding and deburring on conventional lathes. Indeed, you can sand and debur without the direct use of hands (for safety). The tool is fixed to the existing toolpost of the conventional lathes. It allows sanding operations of metal parts, alloy and wood. A manually operated crank allows rotation of the abrasive belt (this index is needed for a more efficient sanding). This tool is designed to fit the different diameters of parts sanded. It also allows quick change abrasive belt (details 4.0).</p>
--	---

<b>2.0</b> <b>Dati tecnici</b>	<b>2.0</b> <b>Technical data</b>
<b>Peso: 2Kg</b>	<b>Weight :2kg</b>

<b>3.0</b> <b>Installazione</b>	<b>3.0</b> <b>Installation</b>
<p><b>Attenzione! La macchina deve essere ferma durante questa operazione.</b></p> <p><b>Il sollevamento può avvenire a mano.</b></p> <p>Posizionare sul carrello mobile del porta utensili della macchina.          Quindi serrare saldamente alla torretta.</p>	<p><b>Warning! The machine must be stopped during this operation.</b></p> <p><b>Can be lifted by hand.</b></p> <p>Position on the movable carriage of the machine tool holder.          Then attach securely to the transverse instrumentation platform.</p>



**-Posizione sul carrello mobile del porta utensili della macchina.**  
**-Position on the tool post**



**N°3 Regolazioni del braccio -N°3 Position**

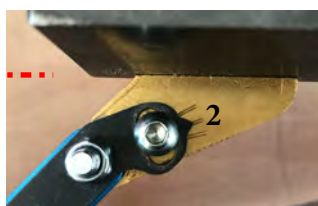

<p>4.0 Funzionamento ed uso</p>	<p>4.0 Operation and use</p>
<p><b>La posizione iniziale, quindi avviare il mandrino in senso antiorario (per la normale lavorazione) e chiudere delicatamente la cinghia abrasiva così si ottiene il posizionamento di lavoro come illustrato in foto. Poi ruotare lentamente la maniglia per avvicinare al pezzo la cinghia abrasiva.</b></p>	<p><b>The initial position , then start the turn counterclockwise (for normal processing) and gently close the abrasive belt finally get working position as illustrated in Then turn slowly the handle to index the abrasive belt as needed.</b></p>

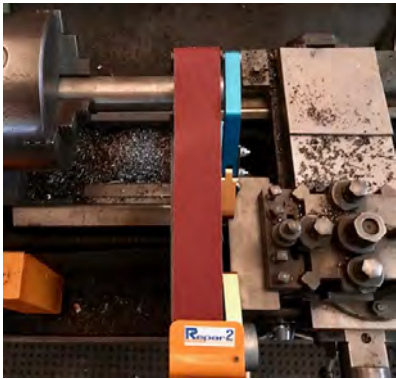

**Initial position**



**Working position**

**ATTENZIONE:**

**È strettamente proibito, utilizzare qualsiasi apparecchio elettrico per accelerare la rotazione della cinghia abrasiva. Solo l'uso della maniglia da parte dell'operatore è consentito. Tutti gli altri modi possono violare la sicurezza dell'operatore.**

**WARNING:**

**It is strictly forbidden, using any electrical appliance to accelerate the rotation of the abrasive belt. Only the use of the handle by the operator is permitted. All other ways may violate a security operator.**



<b>5.0 Certificazione</b>	<b>5.0 Certification</b>
<b>DICHIARAZIONE CE DI CONFORMITA'</b> Con riferimento alle seguenti norme armonizzate:  <b>EN 12840-2001</b> Sicurezza delle macchine utensili. Torni a comando manuale con o senza comando automatico  <b>EN ISO 23125:2015</b> Macchine utensili - Sicurezza - Torni	<b>CE DECLARATION OF CONFORMITY</b> with regard to the following harmonised standards:  <b>EN 12840-2001</b> Safety of machine tools. Manually controlled turning machines with or without automatic control.  <b>EN ISO 23125:2015</b> Machine tools - Safety -Turning machines

<b>6.0 Identificazione</b>	<b>6.0 Identification</b>
--------------------------------	-------------------------------

<b>Targhetta identificativa</b>	<b>Identification plate</b>
---------------------------------	-----------------------------



<b>6.1 Controllo qualità</b>	<b>6.1 Quality control</b>
----------------------------------	--------------------------------

STRUTTURA	STRUCTURE	
SUPPORTO	SUPPORT	
VITERIA	SCREWS	

<b>7.0 Manutenzione</b>	<b>7.0 Maintenance</b>
Operazione di pulizia: Acqua e Sapone	Clean with water and soap.
Apertura e chiusura	Opening and closing.
Verifica delle integrità e del serraggio	Verify the integrity and tightness of all fixing screws.

<p>8.0 <b>Condizioni di stoccaggio</b></p>	<p>8.0 <b>Storage conditions</b></p>
<p>Lasciare la protezione nel sacchetto protettivo</p>	<p>Store guard in protective bag until required.</p>

<p>8.1 <b>Smaltimento</b></p>	<p>8.1 <b>Disposal</b></p>
<p>Prima di effettuare operazioni di smaltimento dei componenti che costituiscono il prodotto, consultare il fabbricante, che indicherà le modalità operative nel rispetto dei principi di sicurezza e di <b>sal-vanguardia ambientale</b>. Il prodotto <b>può essere smaltito senza bisogno di ridurlo in pezzi minuti</b>; è sufficiente scollegare i principali gruppi che la compongono e porli sul mezzo di trasporto adibito alla rottamazione. Provvedere al loro smaltimento operando in conformità alle norme vigenti, rivolgendosi agli organismi preposti e/o ad imprese specializzate nella rottamazione e/o nello smaltimento dei rifiuti, affinché avvenga la separazione tra materiale plastico, materiale metallico e componenti che devono essere inviati a raccolte differenziate. È obbligo del datore di lavoro essere a conoscenza delle leggi vigenti in merito nel proprio paese e operare in modo da ottemperare a tali legislazioni. È vietato ed inoltre passibile di sanzioni, abbandonare il prodotto nell'ambiente</p>	<p>Before you dispose of the components that make up the product, contact the manufacturer, who will be able to advise you regarding methods that comply with local environmental regulations. The product can be disposed of without being broken into small parts. Simply disassemble the main groups and bring them to waste collection. Dispose of them in compliance with current regulations, using agencies and/or firms specializing in scrapping and/or waste disposal, so that plastic material, metallic material and components that must be sent to the waste collection are separated. It is the responsibility of the employer to be aware of the laws in force in the country and comply with such legislation. It is also prohibited and punishable by law to leave the product in the environment.</p>

**9.0**  
**Esploso**

**9.0**  
**Exploded View**

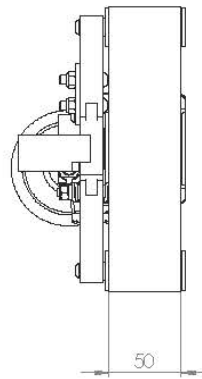
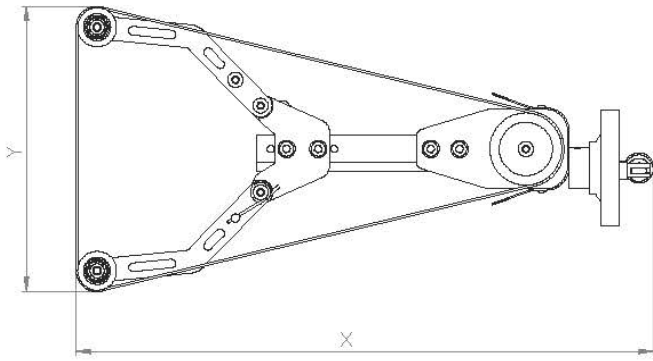

**SPIDER 50**

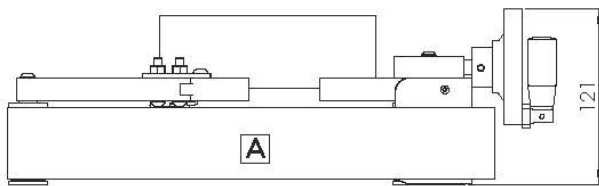

	MIN OPENING	MID OPENING	MAX OPENING
X [mm]	417	400	381
Y [mm]	171	197	227

**BELT [A] :**

**LENGHT:** 900 mm  
**WIDTH:** 50 mm

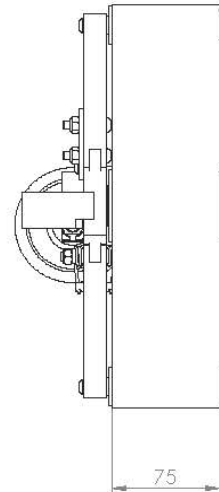
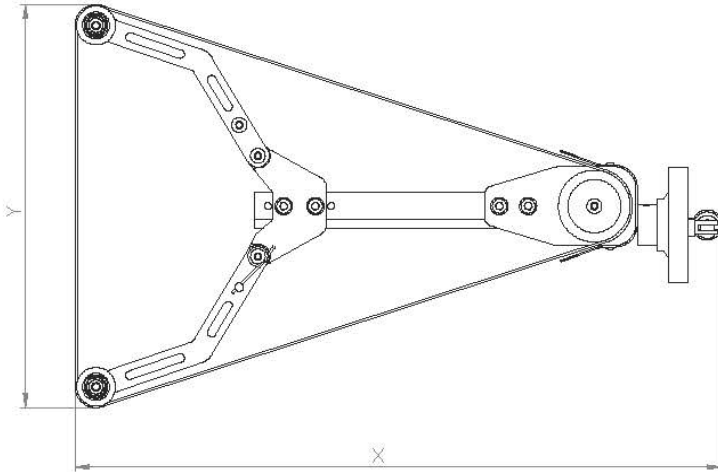

**SPIDER 75**

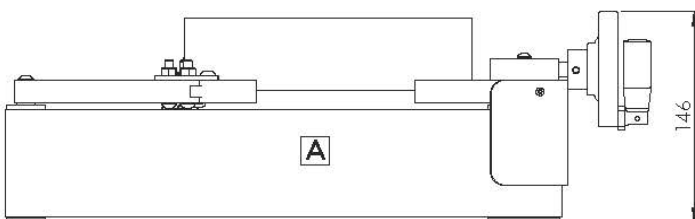

	MIN OPENING	MID OPENING	MAX OPENING
X [mm]	472	450	408
Y [mm]	246	280	336

**BELT [A] :**

**LENGHT:** 1100 mm  
**WIDTH:** 75 mm

10.0

Esempio di montaggio



10.0

Example of assembly



# Repar2

MACHINE GUARDS 

di **Carnovali Marco Ottavio** Via Ambrogio Colombo, 176- 21055 Gorla Minore (VA) – Italy  
 www.repar2.com -info@repar2.com Tel:+39 0331 465727 Fax:+39 0331 465728  
 Exp.Dept: exportoffice@repar2.com

**UCIMU-SISTEMI PER PRODURRE**  
 MEMBER COMPANY

Distributore	Distributor	Distributeur	Distribuidor	Händler
--------------	-------------	--------------	--------------	---------

SELOS, s.r.o.  
 Ludovíta Stárka 16A  
 911 05 Trenčín  
 web: www.kovo-stroje.sk  
 e-mail: predaj@selos.sk  
 Tel.: +421 901 901 715

MANUALE DELLE ISTRUZIONI PER L'USO	MANUAL OF INSTRUCTIONS FOR USE	MANUEL D'INSTRUCTIONS POUR L'UTILISATION	MANUAL DE INSTRUCCIONES DE USO	BEDIENUNGSANLEITUNG
<p>N. volumi: 1            Data: Revisione: 00            ©Copyright 2013 – REPAR2  <b>Senza la preventiva autorizzazione scritta della REPAR2 questo manuale o parte di esso non può essere riprodotto in nessuna forma, modificato, trascritto, tradotto in qualsiasi lingua, reso disponibile a terzi o comunque usato in modo che possa pregiudicare gli interessi della REPAR2. Ogni abuso sarà perseguito ai sensi di legge e sui diritti d'autore.</b></p>	<p>N. volumes: 1            Date: Revision: 00            © Copyright 2013 - REPAR2            Without the prior written permission of REPAR2, this manual or any part of it may not be reproduced in any form, edited, transcribed, translated into any language, made available to third parties or used in a manner that is likely to affect the interests of REPAR2. Any violation will be prosecuted according to law and copyright.</p>	<p>N. volumes: 1            Date: Révision: 00            © Copyright 2013 - REPAR2            Sans l'autorisation écrite préalable de REPAR2 ce manuel ou toute partie de celle-ci ne peut être repro-duit sous quelque forme que modifié, transcrite, traduite dans une autre langue, mis à la disposi-tion des tiers ou utilisées d'une manière qui est susceptible d'affecter les intérêts de la REPAR2 Toute infraction sera pour-suivie conformément à la loi et le droit d'auteur.</p>	<p>N. volúmenes: 1            Fecha: Revisión: 00            © Copyright 2013 - REPAR2            Sin la previa autorización por escrito de REPAR2 este manual o cualquier parte del mismo no puede ser reproducido en cualquier forma, editar, transcribir, traducir a ningún idioma, poner a disposición de terceros ni utilizados de manera que pueda afectar a los intereses de REPAR2 Cualquier violación de éstas normas será perseguida de acuerdo con la ley y los derechos de autor.</p>	<p>Nr. Volumen: 1            Datum: Revision: 00 © Copyright 2013 - REPAR2            Es ist strengstens verboten, diese Anleitung oder Teile davon ohne schriftliche Genehmigung von REPAR2 in keiner Form zu vervielfältigen, ändern, transkribieren, in irgendeiner Sprache übersetzen oder zur Verfügung von Dritten zu stellen oder sie auf eine Weise zu benutzen, dass die Interessen der REPAR2 beeinträchtigt werden. Jeder Verstoß wird nach dem Gesetz und Urheberrecht verfolgt werden.</p>